

## Weather Resistant Vertical Discharge BDD Cap

The Weather Resistant Vertical Discharge BDD Cap is designed for remote located fans.

### STANDARD CONSTRUCTION:

- Damper body and Shell: 18 ga. galvanized
- Blades: .090" Aluminum
- Hinges: Stainless Steel (T-Hinge)
- Angle Ring (I-200-F only): 10 ga carbon steel
- Curb Cap (I-200-C only): 18 ga galvanized
- Rubber Bumper: Damper opens and closes against rubber bumper for more quiet operation.
- Trough: for draining rain, melting ice and snow

### OPTIONS:

- 18 ga 304 Stainless Steel (Body & Shell Only)
- 18 ga 316 Stainless Steel (Body & Shell Only)
- All Aluminum (.090" blades, .063" Body & Shell)

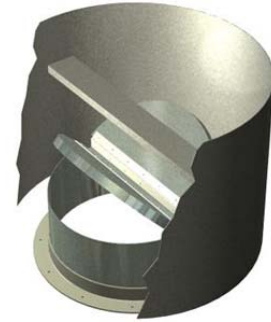

Model I-200-F (shown)

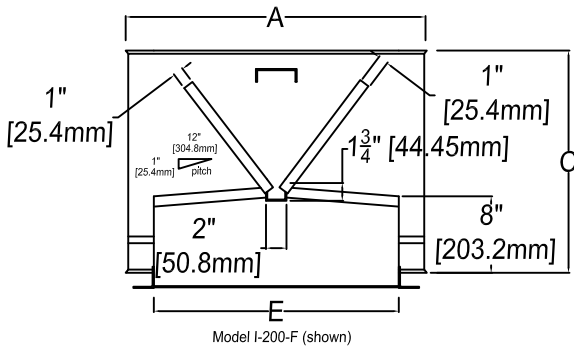

Model I-200-F (shown)

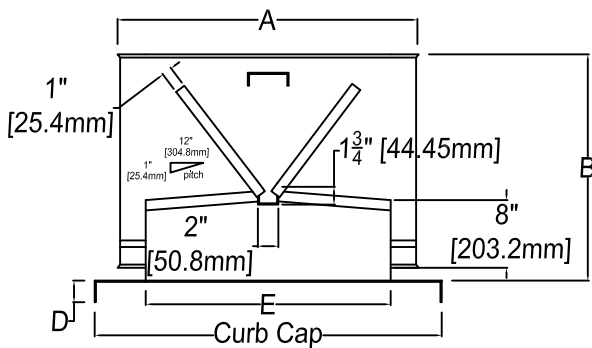

Model I-200-C curb cap style (shown)

Minimum CFM Required To Open Dampers

Model Size	Damper Material		
	Aluminum	Galvanized	Max. CFM
12	1200	1600	2400
14	1500	1900	3200
16	1800	2200	4200
18	2740	3525	4755
20	3160	4085	5746
24	3945	5210	11000
30	6055	7135	14500
36	7625	10975	24000
42	11045	13545	25600
48	12815	16410	43000
54	21425	21440	48000
60	24825	24830	55000

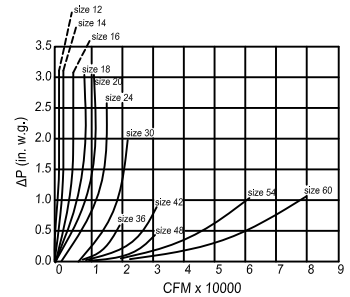

Model Size	A	B	C	D	E	Curb Cap	Recommended Roof Opening
12 [304.8mm]	22" [558.8mm]	16" [406.4mm]	16" [406.4mm]	1-3/4" [44.45mm]	12-3/16" [309.56mm]	22" [558.8mm]	16" [406.4mm]
14 [355.6]	24 [609.6]	18 [457.2]	18 [457.2]	1-3/4 [44.45]	14-3/16 [360.36]	24 [609.6]	18 [457.2]
16 [406.4]	26 [660.4]	20 [508]	20 [508]	1-3/4 [44.45]	16-3/16 [411.16]	26 [660.4]	20 [508]
18 [457.2]	28 [711.2]	22 [558.8]	21 [533.4]	1-3/4 [44.45]	18-3/16 [461.96]	28 [711.2]	22 [558.8]
20 [508]	30 [762]	24 [609.6]	22 [558.8]	1-3/4 [44.45]	20-3/16 [512.76]	30 [762]	24 [609.6]
24 [609.6]	34 [863.6]	26 [660.4]	24 [609.6]	1-3/4 [44.45]	24-3/16 [614.36]	34 [863.6]	28 [711.2]
30 [762]	40 [1016]	30 [762]	27 [685.8]	1-3/4 [44.45]	30-3/16 [766.76]	40 [1016]	34 [863.6]
36 [914.4]	46 [1168.4]	33 [838.2]	29 [736.6]	1-3/4 [44.45]	36-3/16 [919.16]	46 [1168.4]	40 [1016]
42 [1066.8]	52 [1320.8]	38 [965.2]	34 [863.6]	1-3/4 [44.45]	42-3/16 [1071.56]	52 [1320.8]	46 [1168.4]
48 [1219.2]	58 [1473.2]	40 [1016]	36 [914.4]	1-3/4 [44.45]	48-3/16 [1223.96]	58 [1473.2]	52 [1320.8]
54 [1371.6]	64 [1625.6]	45 [1143]	40 [1016]	1-3/4 [44.45]	54-3/16 [1376.36]	64 [1625.6]	58 [1473.2]
60 [1524]	70 [1778]	48 [1219.2]	43 [1092.2]	1-3/4 [44.45]	60-3/16 [1528.76]	70 [1778]	64 [1625.6]

For larger sizes, consult factory

Job Name:

Location:

Architect:

Engineer:

Contractor:

- Model I-200-F** (flanged for curb platform mounting)
- Model I-200-C** (curb cap)

DRAWN BY:

CLJ

DATE:

12-4-03

REV. DATE:

6-19-20

REV. NO.

19

DWG. NO.:

**F-24**